

Intel® 7000 Series Thunderbolt™ 3 Controllers

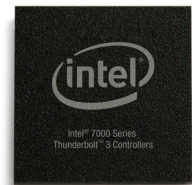

Thunderbolt™ 3: The USB-C That Does It All

Thunderbolt™ 3 delivers a single cable, multi-purpose I/O solution at speeds up to 40 Gbps, creating one compact port that does it all – delivering today's fastest,¹ most versatile connection to any dock, display, or data device. With Thunderbolt 3, one computer port connects to Thunderbolt devices, every display, and billions of USB devices. A single cable now provides four times the data and twice the video bandwidth of any other solution, while also supplying power. It's unrivaled for new uses, such as single-cable docks with charging, docking displays, super-fast storage, external graphics, and 10 GbE networking. Simply put, Thunderbolt 3 delivers the best USB-C.



Thunderbolt Overview

Fundamentally, Thunderbolt is a tunneling architecture designed to combine underlying protocols onto a single interface so that the total speed and performance of the link can be shared between the usages of these protocols allowing Thunderbolt 3 to deliver data, display, and power all over a single cable. Thunderbolt 3 provides more protocols, more speed, more pixels, and more power.

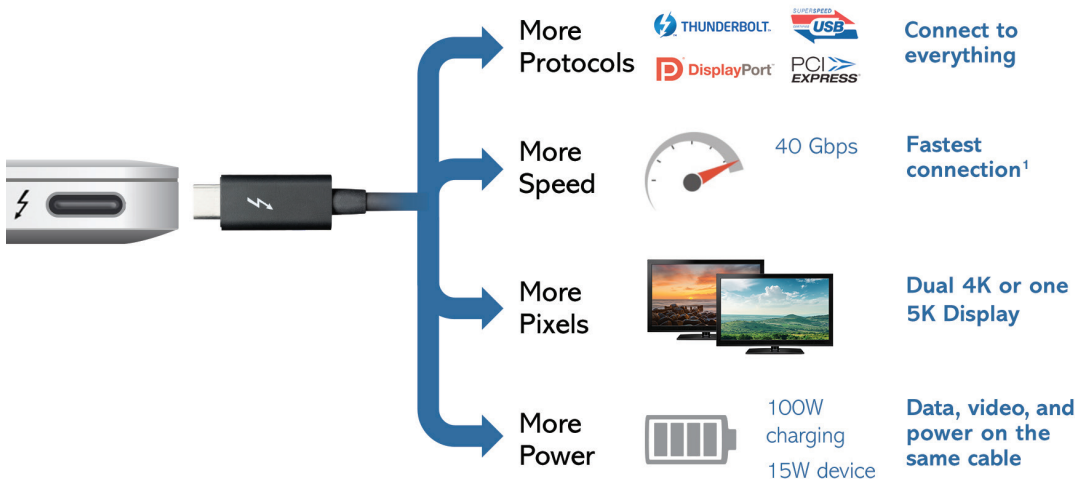

The Thunderbolt controller provides several important features. It includes a physical interface (PHY) layer that can dynamically switch operating modes to drive either:

- Native USB 2.0, USB 3.2 Gen 1 (5 Gbs), USB3.2 Gen 2 (10 Gbs)
- Native DisplayPort* 1.1, 1.2a, and 1.4²
- Thunderbolt at 20 and 40 Gbps

In the Thunderbolt mode, a Thunderbolt 3 port has the ability to support up to two DisplayPort interfaces with support for DisplayPort 1.4 and up to 4 lanes of PCI Express* Gen 3. If the Thunderbolt peripheral device has two Thunderbolt ports, the dynamic mode configuration described above will be configured on the downstream or second port of the device when another cable and device are plugged in to it. Each mode will still be supported on this downstream connector, and data and display traffic will be provided as needed to that downstream port. If each consecutive device is a Thunderbolt device, up to six devices in a chain can be supported.

The Intel® 7440 Thunderbolt™ 3 Controller brings a new capability for peripheral device manufacturers which enables them to design devices which can connect to both Thunderbolt 3 and USB-C based computer ports. Companies can deliver industry leading device functionality with Thunderbolt 3 based computers and provide basic compatibility for USB-C based computers. This feature allows new classes of Dock, Docking Monitor, and Storage which can provide leading performance and broad compatibility.

Key Features and Benefits

More Speed

Provides a 40 Gbps connection

- Double the speed of Thunderbolt™ 2 and 8x the bandwidth of USB 3.0
- Provides a connection with 40 Gbps of bandwidth in each direction

More Protocols

Thunderbolt 3, USB, DisplayPort, and power over one cable

- 4 lanes of PCI Express Gen 3
 - Great for the fastest storage, External Graphics (eGfx), 10 Gb Ethernet, and more
 - Provides the Lowest latency for PCI Express audio
- Supports 2 video streams and DisplayPort 1.4: 8 lanes of HBR2, 4 lanes of HBR3
 - Supports two uncompressed 4K displays (4096 x 2160 30bpp @ 60 Hz)
 - Allows connection of DVI, HDMI, and VGA displays via converters
- Includes a USB 3 connection at up to 10 Gbs
 - Compatible with existing USB devices and cables
- Includes Thunderbolt™ Networking
 - Provides greater than 10 Gb Ethernet bandwidth connection between computers

More Power

Delivers Power to Computer or Peripheral (based on USB power delivery)

- Up to 100W system charging
- 15W to bus-powered devices

Utilizes the USB-C connector for a small, reversible, easy to use solution

There are three components in the Intel® 7000 Series Thunderbolt™ 3 controller family. The block diagram below showcases the peripheral device SKUs use in a Thunderbolt 3 device.

Intel® 7000 Series Thunderbolt™ 3 Controller

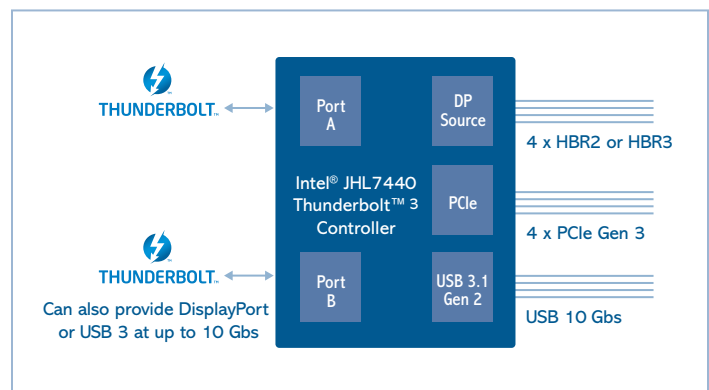

Intel® 7000 Series Thunderbolt™ 3 Controller Technical Specifications

SKU Details

Product Name	Intel® 7540 Thunderbolt™ 3 Controller	Intel® 7440 Thunderbolt™ 3 Controller	Intel® 7340 Thunderbolt™ 3 Controller
Product Number	JHL7540	JHL7440	JHL7340
Order Number: Tape and Reel	964276 – SLMHS	964470 – SLMJ2	964393 – SLMHY
Order Number: Tray	964275 – SLMHR	964458 – SLMHZ	964383 – SLMHX
Expected Usage	Computer	Peripheral device	Computer

Thunderbolt Features

Speed	40 Gbps	40 Gbps	40 Gbps
Thunderbolt Ports	2	2	1
Downstream PCIe Lanes in Device Configuration	N/A	4	N/A
DisplayPort* Streams	Host Configuration: 2 Peripheral Configuration: N/A	Host Configuration: 2 Peripheral Configuration: 2 Tunneled, 1 dedicated DP output	Host Configuration: 2 Peripheral Configuration: N/A
DisplayPort Total Lanes	8 HBR2, 4 HBR3	8 HBR2, 4 HBR3	8 HBR2, 4 HBR3
USB Compatibility	Host port is compatible with USB devices	Upstream port is compatible with USB-C based hosts. Downstream port is compatible with USB devices. USB 3.1 Gen 2 downstream port is also provided.	Host port is compatible with USB devices

Physical Characteristics

Dimensions (HxWxD)	10.7mm x 10.7mm	10.7mm x 10.7mm	10.7mm x 10.7mm
Weight	.23g	.23g	.23g
Operating Temperature	0 – 65 deg C	0 – 65 deg C	0 – 65 deg C
Humidity Non-Operating	MSL3	MSL3	MSL3
Operating Systems Supported	Microsoft Windows* 10, MacOS*, Linux* (certain distributions)	Microsoft Windows* 10, MacOS*, Linux* (certain distributions)	Microsoft Windows* 10, MacOS*, Linux* (certain distributions)